

Multimeter | Desktop Ampere meter VC97 model



مشخصات فنی مولتی متر رومیزی:

ولتاژ DC: 400mV/4V/40V/400V/1000V

ولتاژ AC: 400mV/4V/40V/400V/750V

جریان DC: 400uA/4000uA/40mA/400mA/10A

جریان AC: 400uA/4000uA/40mA/400mA/10A

مقاومت: 400Ω/4kΩ/40kΩ/400kΩ/4MΩ/40MΩ

خازن سنج: 4nF/40nF/400nF/4uF/40uF/200uF



فرکانس متر: 100/1000/10k/100k/1M/30MHz

اندازه گیری دما: -40~1000°C

Overload protection: 250V DC/AC peak value

**ELECTRICAL
SPECIFICATIONS**

Diode and continuity Test

Range	Description	Test Condition
	Display read approx. forward voltage of diode	Forward DC Current approx. 0.5mA. Reversed voltage approx. 1.5V.
	Buzzer sounds if resistance Between terminals V/ Ω and COM is less than about $70 \pm 30 \Omega$.	Open circuit voltage: 0.5V

Overload Protection : 250V DC/AC peak value

Warning: do not input voltage at the range for safety.

Transistor hFE Test

Range	Displaying value	Test condition
hFE NPN or PNP	0~1000	Base Current approx. 15uA, Vce approx. 1.5V

Temperature

Range	Displaying value	Test condition
(-20-1000)°C	<400°C ± (1.0%+5d) ≥400°C ± (1.5%+15d)	1°C

DC Voltage

Range	Accuracy	Resolution
400mV	±(0.5%+4d)	0.1mV
4V		1mV
40V		10mV
400V		100mV
1000V	±(1.0%+6d)	1V

Input impedance: 400mV range: more than 40MΩ other range: 10MΩ

Overload protection: 1000V DC or AC peak value

DC mV:

Range	Accuracy	Resolution
400mV	±(0.5%+4d)	0.1mV

AC Voltage

Range	Accuracy	Resolution
4V	±(0.8%+10d)	1mV
40V		10mV
400V		100mV
750V	±(1.0%+10d)	1V

Input impedance: 400mV range: more than 40MΩ; other range: 10MΩ

Frequency response: 750V range : 40-100Hz other range: 40-400Hz

Overload protection: 1000DC/750VAC RMS

Indication : mean value response (rms of sine wave)

Resistance

Range	Accuracy	Resolution
400 Ω	$\pm (0.8\%+5d)$	0.1 Ω
4k Ω	$\pm (0.8\%+4d)$	1 Ω
40k Ω		10 Ω
400k Ω		100 Ω
4M Ω		1k Ω
40M Ω	$\pm (1.2\%+10d)$	10k Ω

Overload protection: 250V DC/AC peak value

Open circuit voltage: 400mV

Note: at 400 Ω range, should short the test leads and measure the resistance of the wire, then, minus from measuring.

DC Current

Range	Accuracy	Resolution
400uA	$\pm (1.0\%+10d)$	0.1uA
4000uA		1uA
40mA	$\pm (1.2\%+8d)$	10uA
400mA		100uA
10A	$\pm (1.2\%+10d)$	10mA

Overload protection : 0.5A/250V fuse, 10A/250V fuse.

Max measuring voltage: Full scale mA range: 1.2V; A range : 100 mV

Max input current: 10A (max. up to 15 seconds).

AC mV

Range	Accuracy	Resolution
400mV	$\pm(1.6\%+8d)$	0.1mV

AC Current

Range	Accuracy	Resolution
400uA	$\pm(1.5\%+10d)$	0.1uA
4000uA		1uA
40mA		10uA
400mA		100uA
10A	$\pm(2.0+15d)$	10mA

Overload protection : 0.5A/250V fuse, 10A/250V fuse

Max measuring voltage: Full scale mA range: 1.2V A range: 100mV

Max input current: 10A (up to 15 seconds).

Frequency response: 10A range: 40-100Hz; other range: 40-400Hz

Capacitance

Range	Accuracy	Resolution
4nF	$\pm(2.5\%+20d)$	1pF
40nF	$\pm(3.5\%+8d)$	10pF
400nF		100pF
4uF		1nF
40uF		10nF
200uF	$\pm(5.0\%+10d)$	100nF

Overload protection : 250V DC/AC peak value

Frequency

Range	Accuracy	Resolution
100Hz	$\pm (0.5\%+10d)$	0.01Hz
1000Hz		0.1Hz
10kHz		1Hz
100kHz		10Hz
1MHz		100Hz
30MHz		1kHz

DIGITAL MULTIMETER OPERATION MANUAL

1. INTRODUCTION

The instrument is a stable and high performance digital multimeter driven by battery. It uses the LCD with 42mm high make the reading is clearly. And the function of backlight and overload protection make operation is convenient.

The instrument has the function of measuring DCV, ACV, DCA, ACA, Resistance and Capacitance, Frequency, temperature, Transistor, Diode and Continuity test. The instrument takes dual-integral A/D converter as key point, is an excellent tools. It's an ideal tool for lab, factory and family.

2. SAFETY NOTES

This series meter meets the standard of IEC1010. Read it before operation.

- Do not input the limited voltage of 1000V DC or 750V AC RMS when measuring voltage.
- Voltage less than 36V is safety voltage. When measuring voltage higher than 36V DC, 25V AC, check the connection, insulation of test leads to avoid electric shock.
- When changing function and range, test leads should be removed from testing point.
- Select correct function and range.
- When measuring current, do not input current over 20A.
- Safety symbols

“” exists high voltage, “” GND, “” dual insulation, “” must refer to manual, “” low battery

3. SPECIFICATIONS

3.1 GENERAL SPECIFICATIONS

Display mode: LCD displaying.

Max. indication :3999 (3 3/4) , auto polarity indication

Measuring method: Dual-slop integrating A/D converter system.

Sampling rate: Approx. 3times/second

Over range indication: “ OL”

Low battery : The “” displays.

Operating environment: Temperature (0 ~ 40)°C, humidity<80%RH.

Power: 9V battery.

Dimension: 190mm×88.5mm ×27.5mm.

Weight: approx 420g(include battery).

Accessories: Operation manual ,holster, gift box, TP01 thermocouple, test leads, 9V battery.

3.2 ELECTRICAL SPECIFICATIONS

Accuracy is $\pm(\text{RDG} \times a\% + \text{the lowest digit})$ at (23±5)°C, <75%RH.

DC Voltage

Range	Accuracy	Resolution
400mV	±(0.5%+4)	0.1mV
4V		1mV
40V		10mV
400V		100mV
1000V	±(1.0%+6)	1V

Input impedance: 400mV range >40MΩ other range: 10MΩ

Overload protection: 1000V DC or 750V AC peak value

DC mV:

Range	Accuracy	Resolution
400mV	±(0.5%+4)	0.1mV

AC mV (True RMS)

Range	Accuracy	Frequency range	Resolution
400mV	±(1.6%+8)	40Hz-1kHz	0.1mV

ACV (True RMS)

Range	Accuracy	Frequency Range	Resolution
4V	±(0.8%+10)	40Hz-1kHz	1mV
40V			10mV
400V			100mV
750V			1V

Input impedance: 400mV range >40MΩ; other range: 10MΩ

Overload protection: 1000V DC/750V AC peak value.

Frequency response: 40Hz-1kHz (apply to standard sine wave and triangular wave.)

Display: True RMS (the wave more than 200Hz is for reference only)

DCA

Range	Accuracy	Resolution
400uA	±(1.0%+10)	0.1uA
4000uA		1uA
40mA	±(1.2%+8)	10uA
400mA		100uA
10A	±(1.2%+10)	10mA

Max. measuring voltage drop: Full scale mA range: 400mV; A range : 100 mV

Max. input current: 10A (less than 10 seconds).

Overload protection: 0.5A/250V fuse, 10A/250V fuse.

ACA (True RMS)

Range	Accuracy	Frequency Range	Resolution
400uA	±(1.5%+10)	40Hz-1kHz	0.1uA
4000uA			1uA
40mA			10uA
400mA			100uA
10A	±(2.0%+15)		10mA

Max. measuring voltage drop: Full scale mA range: 400mV ; A range: 100mV

Max. input current: 10A (less than 15 seconds).

Overload protection: 0.5A/250V fuse, 10A/250V fuse

Frequency response: 40Hz-1kHz; (apply to standard sine wave and triangular wave.

the wave more than 200Hz is for reference only)

Resistance

Range	Accuracy	Resolution
400Ω	±(0.8%+5)	0.1Ω
4kΩ		1Ω
40kΩ		10Ω
400kΩ		100Ω
4MΩ		1kΩ
40MΩ		±(1.2%+10)

Overload protection: 250V DC/AC peak value

Open circuit voltage: 400mV

Note: at 400Ω range, the test leads should be short-circuit, and measure the down-lead resistance ,then, subtract from the real measuring.

Capacitance

Range	Accuracy	Resolution
10nF	±(5.0%+20)	10pF
100nF		100pF
1u F		1nF
10uF		10nF
100uF		100nF
1mF/10mF/100 mF	±(5.0%+10)	1 uF/10 uF/100 uF

Range	Accuracy	Resolution
10nF	±(5.0%+20)	10pF
100nF		100pF
1u F		1nF
10uF		10nF
100uF		100nF
1mF/10mF/100 mF	±(5.0%+10)	1 uF/10 uF/100 uF

Overload protection : 250V DC/AC peak value

Frequency

Range	Accuracy	Resolution
100Hz	±(0.5%+10)	0.01Hz
1000Hz		0.1Hz
10kHz		1Hz
100kHz		10Hz
1MHz		100Hz
30MHz		1kHz

Input sensitivity: 1.5V

Overload protection: 250V DC/AC peak value

Diode and continuity Test

Range	Displaying value	Test Condition
	Positive voltage drop of diode	The positive DC Current is approx.0.5mA. negative voltage is approx. 1.5V.
	Buzzer sounds ,the resistance Is less than 40±30Ω .	Open circuit voltage: 0.5V

Overload Protection : 250V DC/AC peak value

Warning: do not input voltage at the range for safety.

Temperature

Range	Displaying value	Test condition
(-20-1000)°C	<400°C ±(1.0%+5) ≥400°C ±(1.5%+15)	1°C
(-4-1832)°F	<752°F ±(1.0%+5) ≥752°F ±(1.5%+15)	1°F

Sensor: K type

Warning: do not input voltage at the range for safety.

4. OPERATION

4.1 FRONT PANEL AND DESCRIPTION

1.LCD: display the measuring value and unit.

2.Function key

2-1. “select” key : select DC/AC ,frequency and

Duty cycle . Hz/DUTY Key: when measure DCA,press the key to switch ACA.When measure frequency ,press the key to switch frequency/duty cycle(1~99%).

2-2. RANGE Key: select working mode of automatic measurement and manual measurement.the default mode is automatic measurement and “AUTO” is displayed ,press the key turn into manual measurement ,press the key for 2 sec. will return to automatic measurement condition.

2-3. press the key at voltage ,current and capacitance range, reading is reset and enter into relative value measurement ,LCD displaying “REL” symbol,press it again will exit the function.

2-4.HOLD Key:Press the key ,the present value is held on LCD and display “HOLD” ,press it again will exit the function ; Press the key for 2 sec. will turn to the backlight.

3.Rotary Switch:selecting measuring function and range.

4.Voltage, Resistance, Frequency socket.

5.GND.

6.COM for measuring current less than 400mA.

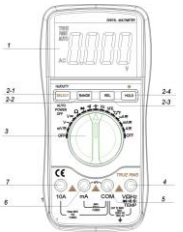

7. COM for measuring current 10A.

4.2 DCV measurement

- 1) Insert the BLACK test lead to “COM” jack and RED test lead to the “V Ω Hz” jack.
- 2) Set the FUNCTION switch to “ $\sqrt{\text{---}}$ ” range.
- 3) The default range is Auto range, and “AUTO” is displayed. Pressing RANGE key switch to manual range, 400mV/4V/40V/400V/1000V can be selected.
- 4) Connect the test leads to the tested point, the voltage and polarity which connected with the red lead will appear on LCD.

Note:

- 1) Manual measurement if LCD display "OL", it means over range, should set the range knob to a higher range.
- 2) Do not measure DCV over 1000V, or, the meter will be damaged.
- 3) Caution to avoid contact with high voltage circuits when measuring high voltage.

4.3. DC mV measurement

- 1) Insert the BLACK test lead to “COM” jack and RED test lead to the “V Ω Hz” jack.
- 2) Set the FUNCTION switch to “mV” range.
- 3) Measuring the voltage less than 400mV and no automatic measurement function at this range.
- 4) Connect the test leads to the tested point, the voltage and polarity which connected with the red lead will appear on LCD.

Note:

- 1) If LCD display "OL", it means over range, should set the range knob to a higher range.
- 2) Do not measure DCV over 1000V, or, the meter will be damaged.
- 3) Caution to avoid contact with high voltage circuits when measuring high voltage.

4.4. AC mV RMS measurement

- 1) Insert the BLACK test lead to “COM” jack and RED test lead to the “V Ω Hz” jack.
- 2) Set the FUNCTION switch to “mV” range, press the “select” key. LCD display ACmV, no automatic measurement function at this range. Do not measure voltage over 400mV.
- 3) Connect the test leads to the tested point, the voltage of the two points which connected with the test leads will appear on LCD.

Note:

- 1) If LCD display "OL", it means over range, should set the range knob to automatic AC voltage.
- 2) Do not measure AC over 400mV, or, the meter will be damaged.

4.5. ACV RMS measurement

- 1) Insert the black test lead to “COM” jack and the red one to “V Ω Hz” jack.
- 2) Set the function switch to “ $\sqrt{\text{~}}$ ” range.
- 3) The default range is Auto range, and “AUTO” is displayed. Pressing RANGE key switch to manual range, 400mV/4V/40V/400V/700V can be selected.
- 4) Connect the test leads to the test point, the voltage of the two points which connected with the test leads will appear on LCD.

Note:

- 1) Manual measurement, If LCD display "OL", it means over range, should set the range knob to a higher range.
- 2) Do not measure ACV over 750V, or, the meter will be damaged.
- 3) Caution to avoid contact with high voltage circuits when measuring high voltage.

4.6. DCA measurement

- 1) Insert the BLACK test lead to “COM” jack and RED test lead to the “mA”(max. 400mA) or "10A" jack (max. 10A).
- 2) Set the FUNCTION switch to current range. Press “SELECT” key to select DC measure mode, connect the leads across to the tested circuit, the current value and polarity the red lead connect with will appear on LCD.

Note:

- 1) If the current range is unknown beforehand, set the FUNCTION switch to a high range and work down.
- 2) When only the figure "OL" is displayed over range is being indicated and the FUNCTION switch must be set to a higher range.
- 3) The max input current is 400mA or 10A depending upon the jack used.
Excessive current will blow the fuse.
- 4) Do not input a value over DCV 36V or ACV 25V on “COM”, “mA” or “A” terminal.

4.7. AC current true RMS measurement

- 1) Insert the BLACK test lead to “COM” jack and RED test lead to the mA”(max. 400mA) or "10A" jack (max. 10A).
- 2) Set the FUNCTION switch to current range. Press “SELECT” key to select AC measure mode, connect the leads across to the tested circuit, the current value will appear on LCD.

Note:

- 1) If the current range is unknown beforehand, set the FUNCTION switch to a high range and work down.
- 2) If LCD display "OL", it means over range, should set the range knob to a higher range.
- 3) The max input current is 400mA or 10A depending upon the jack used.
Excessive current will blow the fuse.
- 4) Do not input a value over DCV 36V or ACV 25V on “COM”, “mA” or “A” terminal.

4.8. Resistance measurement

- 1) Connect the BLACK test lead to “COM” jack and RED test lead to the “V Ω Hz” jack.
- 2) Set the FUNCTION Switch to “ Ω ” range.
- 3) Press "RANGE" to select Auto/Manual measurement.
- 4) If measuring small resistance, should short test leads first, press "REL" one time and measure the unknown resistance measurement, ensure measured value accuracy.

Note:

- 1) To use manual method, if the resistance range is unknown beforehand, set the FUNCTION switch to a higher range and work down.
- 2) If "OL" displays on LCD, it means over-range. When measuring resistance more than 1M Ω , the meter may take a few seconds to stabilize. This is normal for high resistance readings.
- 3) When the input is not connected, i.e. at open circuit, the figure "OL" will be displayed for the over range condition.
- 4) When checking in-circuit resistance, be sure the power has been switched off all capacitors are fully discharged.
- 5) Do not input any voltage at this range.

4.9 .Capacitance measurement

- 1) Set the FUNCTION switch to “ --- ” position.
- 2) Press "REL" once to adjust to zero.
- 3) Connect the tested capacitor to “COM”, “V Ω Hz” input sockets in accordance to the leads (the polarity of the red lead is “+”), the value will be displayed on LCD.
- 4) If the displayed figure on LCD is not zero, press the “REL” key to be reset.

Note:

- 1) Capacitance range have no manual measurement function.
- 2) Before measuring each time, must press "REL" to ensure measure accuracy.
- 3) Discharge all capacitors completely before capacitance measurement to avoid damage.
- 4) 200uF range input reading stable for up to 15 seconds.

4.10. Frequency measurement

- 1) Connect test leads or shield cable to "COM" and "V Ω Hz " jack.
- 2) Set the FUNCTION switch to the "30MHz" range, and connect test leads or cable across the source load under tested.
- 3) Press "Hz/Duty" to switch frequency/duty cycle, and display the reading of frequency or duty cycle.

Note:

- 1) Frequency range have no manual measurement function.
- 2) Do not apply more than 250V DC/AC peak value to the input. Indication is possible at voltage higher than 10V AC rms, but readings may be out of specification.
- 3) In noisy environment, it is preferable to use shield cable for measuring small signal.
- 4) Be caution to avoid contact with high tension circuits when measurement high voltage.

4.11 hFE measurement

- 1) Set the function switch to hFE range.
- 2) Define the transistor is NPN or PNP type, insert the emitter, base and collector separately to the correct hole, the approx. value will be displayed on LCD.

4.12. Diode and continuity Test

- 1) Connect the BLACK test lead to “COM” jack and RED test lead to the “V Ω Hz” jack..
 - 2) Set the FUNCTION switch to “ --- ” position. Press " DC/AC " key which select diode measure method.
 - 3) Forward measure: Connect RED test lead to the positive of the test diode, BLACK test lead to the negative, then, reading of approx. forward voltage of this diode displays.
 - 4) Reverse measure: Connect BLACK test lead to the positive of the test diode, RED test lead to the negative, the mark "OL" will be displayed.
 - 5) Proper diode testing should include both steps.
 - 6) Connect the test probes to two points of circuit, if the resistance is approx. 50 Ω .
Buzzer sounds.
- Note:** Do not input voltage at --- or --- range.

4.13. Temperature measurement

1. Set the function key to “C” range.
 2. Insert the cold-point of the thermocouple to “K TEMP” hole, and the work-point to the place wanted to take temperature, the value will be displayed on LCD.
- NOTE:**
1. When the input terminal is in open circuit, will display the “ normal temp.”
 2. Do not change the thermocouple, or, the accuracy can not be secured.
 3. Do not input voltage at this range.

4.14. Data hold

Press “Hold” key, the current data will display on LCD; Press the key again, will cancel the hold function.

4.15. Backlight

Press hold key for 2 sec. to turn on the backlight , It will be off after 10 sec.

4.16. Auto power off

- 1) Stop working for 15mins, the instrument is auto off and into the sleep mode. The buzzer will sound before power off. Press any key to turn on the power.
- 2) Press “SELECT” key before power on the meter will cancel the function of auto power off .

5. WARNING

- 1) When measuring voltage ensure that instrument is not connected or switched to a current or resistance range, or to the diode check. Always ensure that the correct terminals are used for the type of measurement to be made.
- 2) Take extreme care when measuring voltage above 50V, especially from sources where high energy is existed.

- 3) Avoid making connections to “live” circuits whenever possible.
- 4) When making current measurements ensure that the circuit not “live ”before opening it in order to connect the test leads.
- 5) Before making resistance measurements or diode test, ensure that the circuit under test is de-energized.
- 6) Always ensure that the correct function and range is selected. If in doubt about the correct range to use, start with the highest and work downwards.
- 7) Extreme care should be taken when using the instrument to conjunction with a current transformer connected to the terminals if an open circuit occurs.
- 8) Ensure that the test leads and probes are good condition with no damage to the insulation.
- 9) Take care not to exceed the over-load limits as given in the specification.
- 10) FUSE FOR REPLACEMENT MUST BE OF THE CORRECT TYPE AND RATING.
- 11) Before opening the case of the instrument to replace battery or fuse, disconnect the test leads from any external circuit, set the selector switch to “OFF” position.

6. MAINTENANCE

Do not try to modify the inner circuit.

- 1) Keep the multimeter dry. Keep the multi-meter away from dust and dirt
- 2) Use and store the multi-meter only in normal temperature environments. Temperature extremes can shorten the life of electronic devices, damage batteries, and distort or melt plastic part.
- 3) Handle the multimeter gently and carefully. Dropping it can damage the circuit boards and case and can cause the multi-meter to work improperly although the holster can provide enough protection.
- 4) Wipe the multi-meter with a damp cloth occasionally to keep it looking new. Do not use harsh chemicals, cleaning solvents, or strong detergents to clean the multi-meter.
- 5) Take out off the battery if do not use for a long time. When LCD displays “”, the battery should be replaced.
 - a. Ensure the instrument is not connected to any external circuit. Set the selector switch to OFF position and remove the test leads from terminals.
 - b. Remove the screw on the bottom case and lift the bottom case.
 - c. Remove the spent battery and replace it with a battery of the same type.
- 6) Replace the fuse with same type and rating as the replacements.

NOTE:

- 1) Do not input a voltage over 1000V DC/AC peak value.
- 2) Do not measure voltage at current range, resistance range, diode and buzzer range.
- 3) Do not use the meter if the battery is not replaced well or the battery case is not fixed.
- 4) Before replacing battery or fuse, release the test leads from the test point and turn power off.