



USER MANUAL **IHF01**

Industrial heat flux sensor



Warning statements



Follow the installation instructions of this user manual.



Putting more than 12 Volt across the sensor wiring can lead to permanent damage to the sensor.



Do not use “open circuit detection” when measuring the sensor output.



Do not apply a point load on the sensor.



Twisting the metal sheathed cable might damage it.



Only for supply with the optional CE type examination (ATEX) certificate: ask the supplier for ATEX rated operating conditions.

Contents

Warning statements	2
Contents	3
List of symbols	4
Introduction	5
1 Ordering and checking at delivery	8
1.1 Ordering IHF01	8
1.2 Included items	8
1.3 Quick instrument check	8
2 Instrument principle and theory	9
3 Specifications of IHF01	11
3.1 Dimensions of IHF01	14
4 Standards and recommended practices for use	15
4.1 Heat flux measurement in industry	15
5 Installation of IHF01	16
5.1 Site selection and installation in industry	16
5.2 Electrical connection	18
5.3 Requirements for data acquisition / amplification	19
6 Maintenance and trouble shooting	20
6.1 Recommended maintenance and quality assurance	20
6.2 Trouble shooting	21
6.3 Calibration and checks in the field	22
7 Appendices	23
7.1 Appendix on uncertainty evaluation	23
7.2 Appendix on cable extension / replacement	23
7.3 Appendix on calibration hierarchy	24
7.4 Appendix on black coating	24
7.5 Appendix on correction for temperature dependence	25
7.6 Appendix on measurement range for different temperatures	26
7.7 Appendix on use in (potentially explosive) environments	27
7.8 EU declaration of conformity	28

List of symbols

Quantities

Heat flux
 Voltage output
 Sensitivity
 Temperature
 Thermal resistance per unit area

Symbol

Φ
 U
 S
 T
 $R_{\text{thermal,A}}$

Unit

W/m²
 V
 V/(W/m²)
 °C
 K/(W/m²)

Subscripts

property of the object on which IHF01 is mounted
 maximum allowed value

heatsink
 maximum

Introduction

IHF01 industrial heat flux sensor measures heat flux and temperature, typically in high-temperature industrial environments. IHF01 is waterproof, withstands high pressures and is extremely robust. With signal wires electrically insulated from the sensor body, it complies with industrial safety standards. IHF01 is particularly suitable for trend-monitoring and comparative testing. The same technology can be used to manufacture heat flux sensors for different applications.

IHF01 measures heat flux and surface temperature of industrial equipment like furnaces, boilers, fluidised beds, distillation columns and ovens. The sensors inside IHF01, a thermopile and a thermocouple, are protected by a fully sealed stainless steel body. It is suitable for long term use at one location as well as repeated installation when a measuring system is used at multiple locations. IHF01 measures heat flux through the object on which it is mounted, in W/m^2 , as well as the temperature in $^{\circ}C$. The sensors in IHF01 are a thermopile and a type K thermocouple. The thermopile measures the local heat flux.

The thermocouple measures the absolute temperature of the surface on which IHF01 is mounted, as well as the approximate sensor body temperature. A thermopile and a thermocouple are passive sensors; they do not require power.

The part of the cabling closest to the sensor is a special high-temperature metal sheathed cable with an interlocked spiral stainless steel armour. The sensor as well as the high-temperature cable and armour withstand temperatures up to $900^{\circ}C$. The temperature range is reduced to $650^{\circ}C$ in case the optional black coating is used. The low-temperature extension cable has a jacket of PTFE type plastic.



Figure 0.1 *IHF01 industrial heat flux sensor*

Operation

Using IHF01 is easy. It can be connected directly to commonly used data logging systems. The heat flux, Φ , in W/m^2 , is calculated by dividing the IHF01 output, a small voltage U , by the sensitivity S .

The measurement function of IHF01 is:

$$\Phi = U/S \quad \text{(Formula 0.1)}$$

The sensitivity is provided with IHF01 on its product certificate. Equipped with heavy duty cabling, and having a fully stainless steel casing so that moisture does not penetrate the sensor, IHF01 has proven to be very reliable. It survives long-term outdoor installation.

IHF01 advantages

- robust
- suitable for use at high temperatures
- IP protection class: IP67
- signal wires electrically insulated from the sensor body

Suggested use

trend-monitoring and comparative measurement of heat flux and surface temperature in industrial installations. See also [IHF02](#) for an industrial heat flux sensor with increased sensitivity.

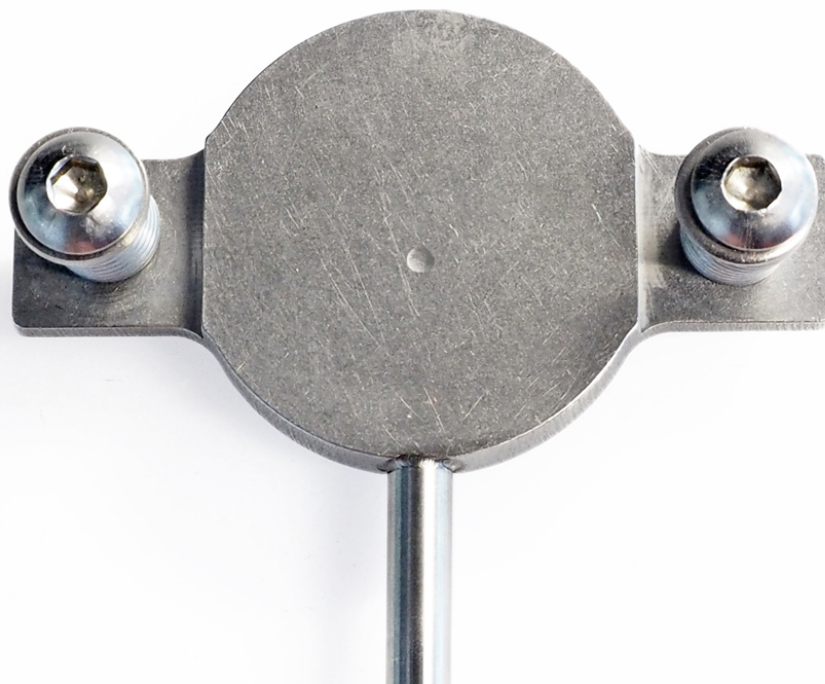

Figure 0.2 *IHF01 industrial heat flux sensor ready for mounting on a well-prepared surface using tack-welded threads and spring-loaded bolts.*

Calibration

IHF01 calibration is traceable to international standards. The factory calibration method follows the recommended practice of ASTM C1130-17.

Trend-monitoring and comparative measurement

IHF01 is most suitable for relative measurements using one sensor, i.e. monitoring of trends relative to a certain reference point in time or comparing heat flux at one location to the heat flux at another location. If the user wants to perform accurate absolute measurements with IHF01, as opposed to relative measurements, the user must make his own uncertainty evaluation and correction for systematic errors. See the appendix on uncertainty evaluation. However, in many situations the analysis of trends is sufficient. In that case a high absolute measurement accuracy is not needed, and a formal uncertainty evaluation is not necessary.

See also

- model [IHF02](#) for an industrial heat flux sensor with increased sensitivity
- model [HF05](#) for a heat flux sensor with a high sensitivity at a lower temperature range
- our complete [range of heat flux sensors](#)
- our [industrial heat flux sensors](#) (PDF)



Figure 0.3 IHF01 industrial heat flux sensor mounted on a wall using tack-welded threads and spring-loaded bolts.

1 Ordering and checking at delivery

1.1 Ordering IHF01

The standard configuration of IHF01 is with 1 metre high-temperature cable and 3 metres low-temperature extension cable.

Common options are:

- longer cable (specify total cable length for both cable types in m)
- black coating
- EC type examination certificate (ATEX) II 2G Ex db IIC T6
- connector at IHF01 cable end
- extension cable with 2 connectors matching cable connector and chassis connector (specify cable length in m)
- chassis connector with internal wiring (colour code of wiring identical to cable colour code)

1.2 Included items

Arriving at the customer, the delivery should include:

- heat flux sensor IHF01
- with cables of the length as ordered
- any other option as ordered
- product certificate matching the instrument serial number

1.3 Quick instrument check

A quick test of the instrument can be done by connecting it to a multimeter.

1. Check the electrical resistance of the heat flux sensor between the black [-] and red [+] wires and the thermocouple between the green [+] and white [-] wires. Measure the sensor resistance first with one polarity, then reverse the polarity. Take the average value. Compare the results with the resistance values on the product certificate. Infinite resistance indicates a broken circuit; zero or a lower than 1 Ω resistance indicates a short circuit.
2. Check if the heat flux sensor reacts to heat: put the multimeter at its most sensitive range of DC voltage measurement. Expose the sensor to a strong heat source, for instance using a heat gun. Exposing the side flush with flanges should generate a positive signal, doing the same at the opposite side, the sign of the output voltage reverses.
Also look at the reaction of the thermocouple to heat.
3. Inspect the instrument for any damage.
4. Check the sensor serial number engraved on the transition piece against the certificate provided with the sensor.

2 Instrument principle and theory

IHF01's scientific name is heat flux sensor. A heat flux sensor measures the heat flux density through the sensor itself. This quantity, expressed in W/m^2 , is usually called "heat flux". IHF01 users typically assume that the measured heat flux is representative of the undisturbed heat flux at the location of the sensor. Users may also apply corrections based on scientific judgement.

The heat flux sensor in IHF01 is a thermopile. This thermopile measures the temperature difference across the stainless steel body of IHF01. Working completely passive, the thermopile generates a small voltage that is a linear function of this temperature difference. The heat flux is proportional to the same temperature difference divided by the effective thermal conductivity of the heat flux sensor body. Using IHF01 is easy. For readout the user only needs an accurate voltmeter that works in the millivolt range. To convert the measured voltage, U , to a heat flux Φ , the voltage must be divided by the sensitivity S , a constant that is supplied with each individual sensor.

The temperature sensor inside IHF01 is a type K thermocouple located at the side of the sensor flush with the flanges.

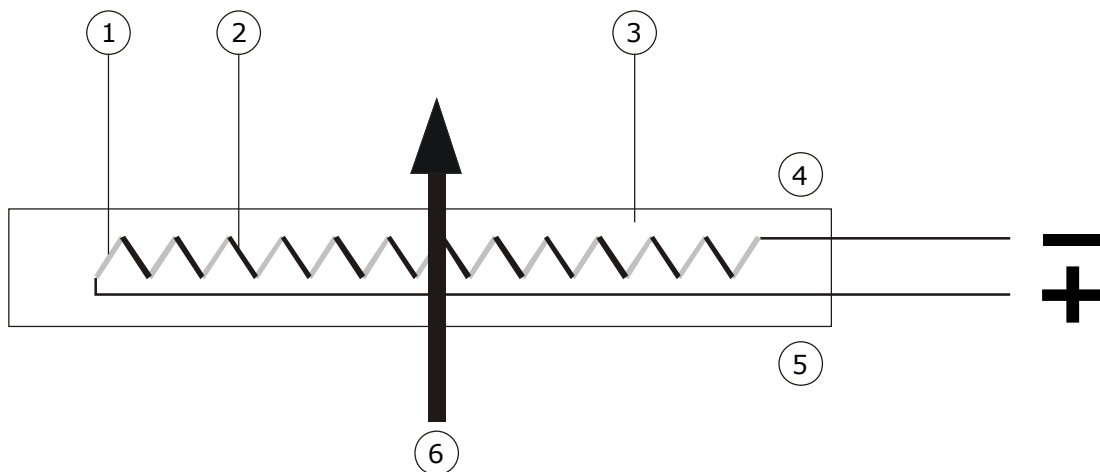

Figure 2.1 The general working principle of a heat flux sensor. The sensor inside IHF01 is a thermopile. A thermopile consists of a number of thermocouples, each consisting of two metal alloys marked 1 and 2, electrically connected in series. A single thermocouple will generate an output voltage that is proportional to the temperature difference between its hot- and cold-joints. Putting thermocouples in series amplifies the signal. In a heat flux sensor, the hot- and cold-joints are located at the opposite sensor surfaces 4 and 5. In steady state, the heat flux 6 is a linear function of the temperature difference across the sensor and the average thermal conductivity of the sensor body, 3. The thermopile generates a voltage output proportional to the heat flux through the sensor. The exact sensitivity of the sensor is determined at the manufacturer by calibration, and is found on the calibration certificate that is supplied with each sensor.

Heat flux sensors such as IHF01, for use in industry, are typically calibrated under the following reference conditions:

- conductive heat flux (as opposed to radiative or convective heat flux)
- homogeneous heat flux across the sensor

The IHF01 factory calibration procedure uses the following reference conditions:

- instrument temperature of 30 °C
- heat flux of $23 \times 10^3 \text{ W/m}^2$
- mounted on a water cooled aluminium heatsink
- thermal conductivity of the surrounding environment 0.0 W/(m·K)

Unique features of IHF01 are:

- robustness, including a strong cable
- suitable for use at high temperatures, up to +900 °C
- built-in temperature sensor; type K thermocouple
- IP protection class: IP67 (essential for outdoor application)
- sensors isolated from housing

Measuring with heat flux sensors, errors may be caused by differences between calibration reference conditions and the conditions during use. The user should analyse his own experiment and make his own uncertainty evaluation.

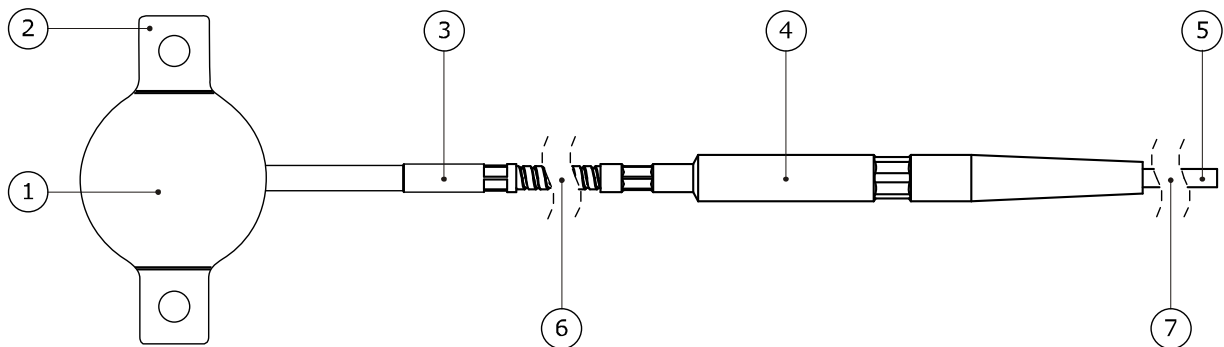

Figure 2.2 IHF01: the heat flux sensor consist of a stainless steel body (1) which is connected via a rigid stainless steel coupler (3) to a flexible high temperature metal sheathed cable with interlocked spiral stainless steel armour (6). After a transition piece (4), wires are extended using a low temperature extension cable (7). In the standard configuration, the cable ends in bare wires (5). Two mounting flanges (2) are attached to the body.

3 Specifications of IHF01

IHF01 measures the heat flux density through the surface of the sensor. This quantity, expressed in W/m^2 , is called heat flux. It also measures the instrument body temperature. IHF01 is passive, using thermopile and thermocouple sensors. The thermopile generates a small output voltage proportional to the heat flux. IHF01 can only be used in combination with a suitable measurement system. The sensor should be used in accordance with the recommended practices of ASTM.

Table 3.1 Specifications of IHF01 (continued on next page)

IHF01 SPECIFICATIONS	
Sensor type	industrial heat flux sensor
Sensor type according to ASTM	heat flow sensor or heat flux transducer
Heat flux sensor	thermopile
Measurand	heat flux
Measurand in SI units	heat flux density in W/m^2
Measurement range	$(-1000 \text{ to } +1000) \times 10^3 \text{ W/m}^2$ see appendix on measurement range for different temperatures
Temperature sensor	thermocouple type K
Temperature sensor specification	EN 60584-1:2013 ASTM E230 / E230M-12
Measurand	temperature
Measurand in SI units	temperature in $^{\circ}C$
Measurement function / required programming	$\Phi = U/S$
Sensitivity range	$5 \text{ to } 15 \times 10^{-9} \text{ V}/(W/m^2)$
Recommended number of sensors	2 per measurement location
Sensitivity (nominal)	$9 \times 10^{-9} \text{ V}/(W/m^2)$
Response time (95 %)	60 s (nominal)
Directional sensitivity	heat flux from the side flush with the flanges the opposite side generates a positive voltage output signal
Expected voltage output	multiply the sensitivity by the maximum expected heat flux
Required readout	heat flux sensor: 1 x differential voltage channel or 1 x single ended voltage channel temperature sensor: 1 x Type K differential thermocouple channel or 1 x Type K single ended thermocouple channel both with input resistance $> 10^6 \Omega$
Rated operating temperature range	-30 to +900 $^{\circ}C$ (sensor and high temperature cable) -30 to +650 $^{\circ}C$ (optional black coating) -30 to +240 $^{\circ}C$ (low temperature extension cable)
IP protection class	IP67
Rated operating relative humidity range	0 to 100 %
Rated operating pressure	10 bar (clamping on transition piece or low temperature extension cable)
Maximum load on sensor	In case of higher process pressure, contact Hukseflux 1000 kg (homogeneously distributed)
Required sensor power	zero (passive sensors)
Temperature dependence	$< 0.1 \text{ \%}/^{\circ}C$

Table 3.1 Specifications of IHF01 (started on previous page)

Non-stability	< 1 %/yr (for typical use)
Sensor diameter	40 x 10 ⁻³ m
Sensor thickness	6 x 10 ⁻³ m
Sensor thermal resistance	0.4 x 10 ⁻³ K/(W/m ²)
Sensor thermal conductivity	15 W/(m·K)
Heat flux sensor resistance (nominal)	100 Ω (standard cable lengths)
Temperature sensor resistance (nominal)	60 Ω (standard cable lengths)
Standard cable lengths	
High-temperature cable	1 m (see options)
Low-temperature extension cable	3 m (see options)
Low-temperature extension cable: heat flux sensor cable resistance	0.1 Ω/m (nominal)
High-temperature cable: heat flux sensor cable resistance	110 Ω/m (nominal)
Low-temperature extension cable: temperature sensor cable resistance	3 Ω/m (nominal)
High-temperature cable: temperature sensor cable resistance	50 Ω/m (nominal)
High-temperature cable diameter	5 x 10 ⁻³ m
Low-temperature extension cable diameter	4.5 x 10 ⁻³ m
Transition piece diameter	10 x 10 ⁻³ m
Marking	1 x engraving on the transition piece, showing serial number
Gross weight including 1 and 3 m cable	approx. 1 kg
Net weight including 1 and 3 m cable	approx. 0.5 kg
Packaging	plastic case
INSTALLATION AND USE	
Typical conditions of use	in measurements in industrial environments. Exposed to high heat fluxes for periods of several minutes to several years. Connected to user-supplied data acquisition equipment. Regular inspection of the sensor surface and housing. Continuous monitoring of sensor temperature. No special requirements for immunity, emission, chemical resistance.
Orientation	the side flush with the flanges must be in contact with the object on which the sensor is mounted
Installation	see recommendations in this user manual. Avoid mechanical force on the flanges, sensor body and sensor-to-cable transition.
Cable extension	see options: longer cables, extension cable and connectors
Optional connectors on IHF01 cable and extension cable	female receptable LEMO PCA.1S.304.CLLC47 male plug LEMO FFA.1S.304.CLAC47
CALIBRATION	
Calibration traceability	to SI units
Product certificate	included (showing calibration result and traceability)
Calibration method	method IHFC, according to ASTM C1130
Calibration hierarchy	From SI through international standards and through an internal mathematical procedure
Calibration uncertainty	± 10 % (k = 2)
Recommended recalibration interval	2 years
Calibration reference conditions	30 °C, heat flux of 23 x 10 ³ W/m ² , mounted on a water cooled aluminium heat sink, thermal conductivity of the surrounding environment 0.0 W/(m·K)

Table 3.1 Specifications of IHF01 (started on previous 2 pages)

Validity of calibration	based on experience the instrument sensitivity will not change during storage. During use the instrument "non-stability" specification is applicable.
Field calibration	is possible by comparison to a calibration reference sensor. Usually mounted side by side. Preferably reference and field sensor of the same model and brand. Typical duration of test > 24 h.
Temperature sensor tolerance class	IEC 60584-1:2013: type K, tolerance class 1
Temperature sensor error limits	according to IEC 60584-1: 2013 or ASTM E230 / E230M -12
MEASUREMENT ACCURACY	
Uncertainty of the measurement	statements about the overall measurement uncertainty can only be made on an individual basis. see the chapter on uncertainty evaluation.
VERSIONS / OPTIONS	
Order code	HF01 - cable length high temperature in m - cable length low temperature extension cable in m
Longer cables	longer cables (specify total cable length for both cable types in m)
EC type examination certificate (ATEX)	II 2G Ex db IIC T6
With black coating	top side of sensor coated black see appendix on black coating
Extension cable	extension cable with 2 connectors matching cable connector and chassis connector (specify cable length in m)
Connector	connector at IHF01 cable end
Chassis connector	chassis connector with internal wiring (colour code of wiring identical to cable colour code)

3.1 Dimensions of IHF01

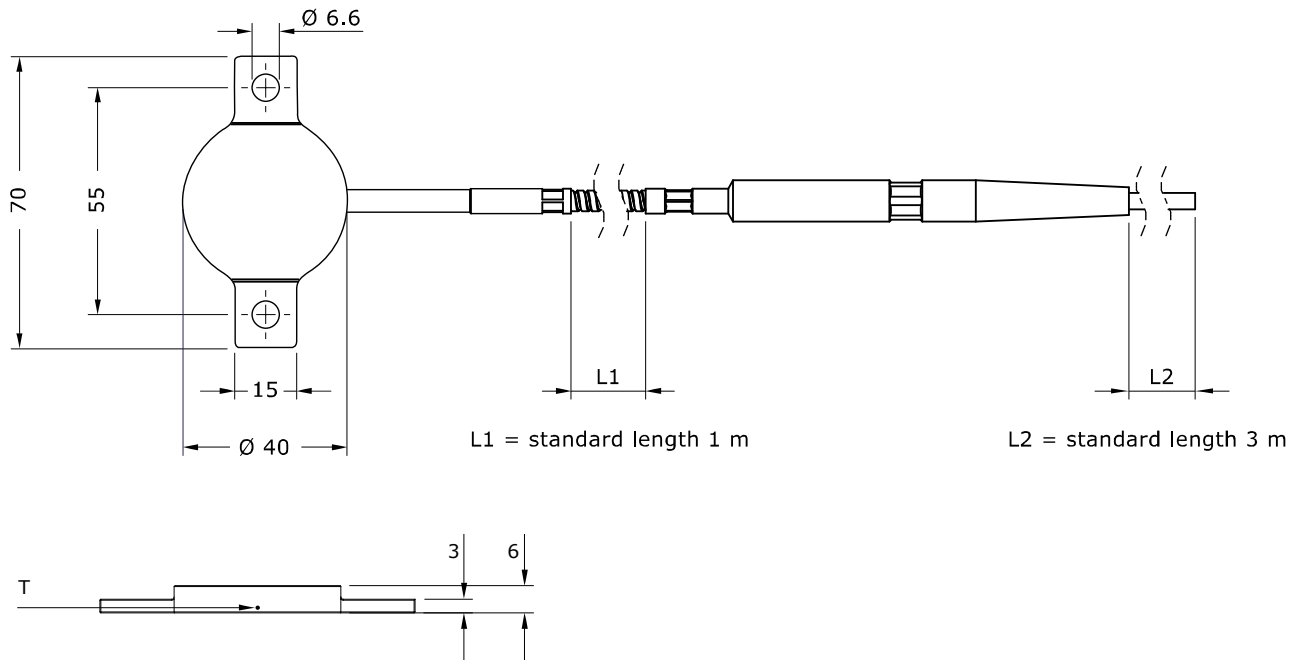

Figure 3.1.1 IHF01 industrial heat flux sensor dimensions in $\times 10^{-3} \text{ m}$. T marks the location of the temperature measurement

4 Standards and recommended practices for use

IHF02 should be used in accordance with the recommendations of this user manual.

See the typical conditions of use in the specifications chapter; discuss any deviations.

4.1 Heat flux measurement in industry

Many IHF01 sensors measure on industrial walls and metal surfaces, estimating the installation's energy balance and the thermal transmission of walls. Typically the total measuring system consists of multiple heat flux- and temperature sensors. In many cases heat flux sensors are used for trend-monitoring. In such cases reproducibility is more important than absolute measurement accuracy.



Figure 4.1.1 Example of an IHF01 industrial heat flux sensor mounted on a wall using spring-loaded bolts and tack-welded threads. The sensor is mounted on a well prepared flat surface.

5 Installation of IHF01

5.1 Site selection and installation in industry

Table 5.1.1 *Recommendations for installation of IHF01 heat flux sensors*

Location	choose a location that is representative of the process that is analysed if possible, avoid exposure to sun, rain, etc. do not expose to drafts and lateral heat fluxes do not mount in the vicinity of thermal bridges, cracks, heating or cooling devices and fans
Performing a representative measurement / recommended number of sensors	we recommend using > 2 sensors per measurement location. This redundancy also improves the assessment of the measurement accuracy
Orientation	mount with the flanges flush with the object, see figure 5.1.1. Mounted on vertical surfaces, the cable exit from the sensor should point down.
Surface cleaning and levelling	create a clean and smooth surface with a diameter of 70×10^{-3} m, so that the air gap between sensor and object surface is less than 0.2×10^{-3} m
Mechanical mounting: using the mounting flanges	the sensor body withstands only limited pressure and strain. users should not exert significant mechanical force on the flanges. tack-weld or screw M6 thread to the surface on which IHF01 is mounted at a hart-to-hart distance of 55×10^{-3} m. Bolts holding the sensor should be used for positioning and for loose fixation only, and should be spring-loaded to guarantee good sensor to surface contact without exerting too much force.
Mechanical mounting: clamping	clamp on the transition piece or low temperature extension cable using a compression fitting
Permanent installation	for long-term installation, fill up the space between sensor and object, for example with high-temperature thread paste (Molykote P37 thread paste, specified rated to 1400 °C) or with a graphite packing material (Egraflex GTC 0.3 mm thickness rated to 450 °C). Use this in combination with the spring-loaded threads. We discourage the use of thermal paste because it tends to dry out.
Signal amplification	see the paragraph on electrical connection
Mounting in high pressure environment	use a sealed compression fitting, either around the transition piece or around the low temperature extension cable

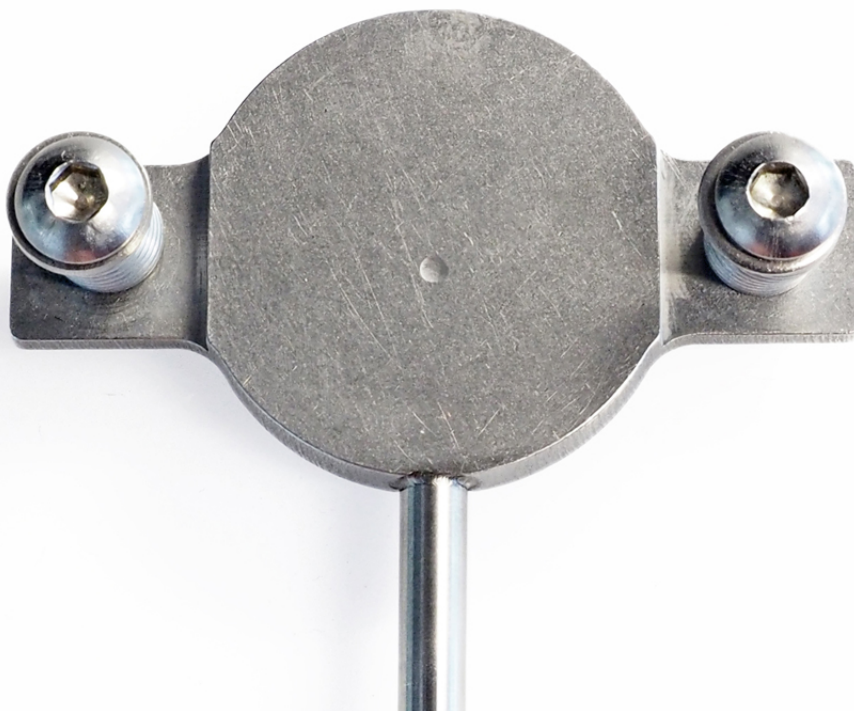

Figure 5.1.1 *Installation of IHF01 with spring-loaded bolts (not included with IHF01) using tack-welds on a well-prepared flat surface*

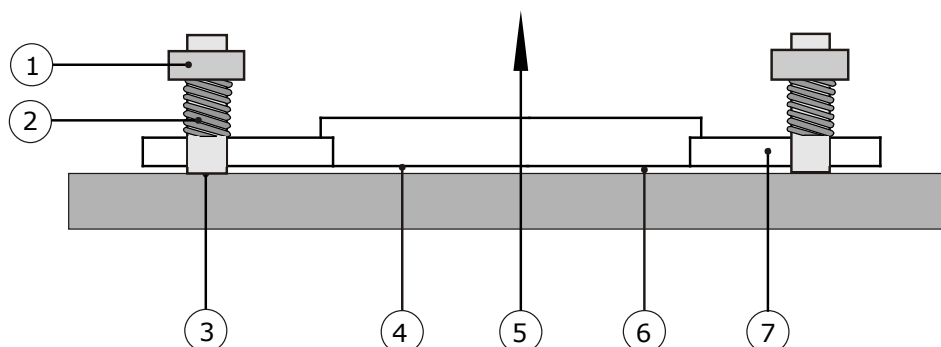

Figure 5.1.2 *Installation of IHF01*

- (1) M6 bolt
- (2) spring loaded M6 thread
- (3) tack-weld
- (4) IHF01 side of object to be measured, flush with flanges
- (5) heat flux generating positive signal
- (6) for long-term installation, apply high-temperature thread paste or a graphite packing material
- (7) mounting flange

5.2 Electrical connection

A heat flux sensor should be connected to a measurement system, typically a so-called datalogger. IHF01 is a passive sensor that does not need any power, neither for the heat flux sensor, nor for the temperature sensor. Cables may act as a source of distortion, by picking up capacitive noise. We recommend keeping the distance between a datalogger or amplifier and the sensor as short as possible. For cable extension, see the appendix on this subject.

Table 5.2.1 *The electrical connection of IHF01. The shield is not connected to the stainless steel sensor body or the cable transition piece*

WIRE	
Red	heat flux signal [+]
Black	heat flux signal [-]
Green	thermocouple type K [+]
White	thermocouple type K [-]
Grey	shield

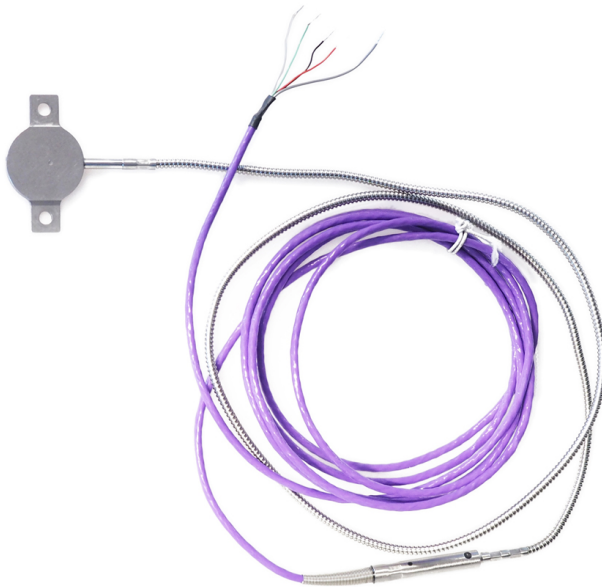

Figure 5.2.1 *IHF01 as delivered in its standard configuration*

5.3 Requirements for data acquisition / amplification

The selection and programming of dataloggers is the responsibility of the user. Please contact the supplier of the data acquisition and amplification equipment to see if directions for use with the IHF01 are available.

Table 5.3.1 *Requirements for data acquisition and amplification equipment for IHF01 in the standard configuration*

Capability to measure small voltage signals	preferably: $< 5 \times 10^{-6}$ V uncertainty Minimum requirement: 20×10^{-6} V uncertainty (valid for the entire expected temperature range of the acquisition / amplification equipment)
Capability for the data logger or the software	to store data, and to perform division by the sensitivity to calculate the heat flux. $\Phi = U/S$ (Equation 0.1)
Capability to measure thermocouple type K	preferably: measurement uncertainty within ± 3 °C
Data acquisition input resistance	$> 1 \times 10^6 \Omega$
Open circuit detection (WARNING)	open-circuit detection should not be used, unless this is done separately from the normal measurement by more than 5 times the sensor response time and with a small current only. Thermopile and thermocouple sensors are sensitive to the current that is used during open circuit detection. The current will generate heat, which is measured and will appear as a temporary offset.

6 Maintenance and trouble shooting

6.1 Recommended maintenance and quality assurance

IHF01 measures reliably at a low level of maintenance. Unreliable measurement results are detected by scientific judgement, for example by looking for unreasonably large or small measured values. The preferred way to obtain a reliable measurement is a regular critical review of the measured data, preferably checking against other measurements.

Table 6.1.1 *Recommended maintenance of IHF01. If possible the data analysis is done on a daily basis.*

MINIMUM RECOMMENDED HEAT FLUX SENSOR MAINTENANCE			
	INTERVAL	SUBJECT	ACTION
1	1 week	data analysis	compare measured data to the maximum possible or maximum expected heat flux and to other measurements for example from nearby or redundant instruments. Historical seasonal records can be used as a source for expected values. Look for any patterns and events that deviate from what is normal or expected. Compare to acceptance intervals.
2	6 months	inspection	inspect cable quality, inspect mounting, inspect location of installation look for seasonal patterns in measurement data
3	2 years	recalibration	recalibration by comparison to a calibration standard instrument in the field, see following paragraphs. recalibration by the sensor manufacturer
4		lifetime assessment	judge if the instrument will be reliable for another 2 years, or if it should be replaced

6.2 Trouble shooting

Table 6.2.1 *Trouble shooting for IHF01*

General	<p>Inspect the sensor for any damage. Inspect the quality of mounting / installation. Inspect if the wires are properly attached to the data logger. Check the condition of the cable. Inspect the connection of the shield (typically connected at the datalogger side). Check the datalogger program in particular if the right sensitivity is entered. IHF01 serial number is engraved on the side of the sensor body. The sensitivity can be found on the product certificate.</p> <p>Check the electrical resistance of the heat flux sensor between the black [-] and red [+] wires and the thermocouple between the green [+] and white [-] wires. Measure the sensor resistance first with one polarity, then reverse the polarity. Take the average value. Compare the results with the resistance values on the product certificate. Infinite resistance indicates a broken circuit; zero or a lower than 1 Ω resistance indicates a short circuit.</p>
The sensor does not give any signal	<p>Check if the heat flux sensor reacts to heat: put the multimeter at its most sensitive range of DC voltage measurement. Expose the sensor to a strong heat source, for instance using a heat gun. Exposing the side flush with flanges should generate a positive signal, doing the same at the opposite side, the sign of the output voltage reverses.</p> <p>Also look at the reaction of the thermocouple to heat. Check the data acquisition by replacing the sensor with a spare unit.</p>
The sensor signal is unrealistically high or low	<p>Check the cable condition looking for cable breaks. Check the data acquisition by applying a 1×10^{-6} V source to it in the 1×10^{-6} V range. Look at the measurement result. Check if it is as expected. Check the data acquisition by short circuiting the data acquisition input with a 10 Ω resistor. Look at the output. Check if the output is close to 0 W/m².</p>
The sensor signal shows unexpected variations	<p>Check the presence of strong sources of electromagnetic radiation (radar, radio). Check the condition and connection of the shield. Check the condition of the sensor cable. Check if the cable is not moving during the measurement.</p>

6.3 Calibration and checks in the field

The recommended calibration interval of heat flux sensors is 2 years.
Recalibration of field heat flux sensors is ideally done by the sensor manufacturer.

On-site field calibration is possible by comparison to a calibration reference sensor, usually mounted side by side, alternatively mounted on top of the field sensor.

Hukseflux main recommendations for field calibrations are:

- 1) to compare to a calibration reference of the same brand and type as the field sensor
- 2) to connect both to the same electronics, so that electronics errors (also offsets) are eliminated.
- 3) to mount all sensors on the same platform, so that they have the same body temperature.
- 4) typical duration of test: > 24 h
- 5) typical heat fluxes used for comparison: > $2 \times 10^3 \text{ W/m}^2$, preferably > $20 \times 10^3 \text{ W/m}^2$
- 6) to correct deviations of more than $\pm 20 \%$. Lower deviations should be interpreted as acceptable and should not lead to a revised sensitivity.

7 Appendices

7.1 Appendix on uncertainty evaluation

If the user wants to perform accurate absolute measurements, as opposed to relative measurements, we recommend that the user calibrates sensors under his own responsibility under "simulated service conditions", and make his own correction for systematic errors and uncertainty evaluation.

The uncertainty of a measurement with IHF01 is a function of:

- calibration uncertainty
- differences between reference conditions during calibration and measurement conditions, for example uncertainty caused by temperature dependence of the sensitivity
- the duration of sensor employment (involving the non-stability)
- application errors: the measurement conditions and environment in relation to the sensor properties, the influence of the sensor on the measurand, the representativeness of the measurement location

If the user knows the total power generated by a process the user may calibrate the heat flux measurement by comparison of heat fluxes multiplied by surface areas to the total generated power. Some users apply (temporary) electrical heaters to calibrate the sensors.

However, in many situations the analysis of trends is sufficient. In that case a high absolute measurement accuracy is not needed, and a formal uncertainty evaluation is not necessary.

7.2 Appendix on cable extension / replacement

IHF01 is equipped with a high temperature cable and a low temperature extension cable. The standard configuration of IHF01 is with 1 m high temperature cable and 3 m low temperature extension cable. Cable length of both cable types can be specified when ordering.

Keep the distance between data logger or amplifier and sensor as short as possible. Cables may act as a source of distortion by picking up capacitive noise. In an electrically "quiet" environment the IHF01 cable may be extended without problem to 50 metres. If done properly, the sensor signal, although small, will not significantly degrade because the sensor resistance is very low (which results in good immunity to external sources) and because there is no current flowing (so no resistive losses). Cable and connection specifications are summarised in table 7.2.1.

Table 7.2.1 Preferred specifications for cable extension of IHF01

Cable	Hukseflux IHF01 high temperature cable (not extendable) Hukseflux IHF01 low temperature extension cable
Extension	use Hukseflux IHF01 extension cable with 2 connectors matching cable connector and chassis connector (specify cable length in m) use Hukseflux chassis connector
Outer diameter	4.5×10^{-3} m (low temperature extension cable)
Length	cables should be kept as short as possible, in any case the total cable length should be less than 50 m

7.3 Appendix on calibration hierarchy

IHF01 factory calibration is traceable from SI through international standards and through an internal mathematical procedure which corrects for known errors. The formal traceability of the generated heat flux is through voltage and current to electrical power and electric power and through length to surface area.

The Hukseflux IHFC method follows the recommended practice of ASTM C1130-07. It relies on a thin heater apparatus according to principles as described in paragraph 4 of ASTM C1114-06, in the single sided mode of operation described in paragraph 8.2 and in ASTM C1044-16.

7.4 Appendix on black coating

In some applications, it may be desirable for the emissivity of the sensor surface to be more representative of the surroundings.

In these cases, the top side of the sensor may be coated black. Most black paints have an emission of above 0.9.

IHF01 can be delivered with the black coating on the top side of the sensor as an option. The temperature range of the sensor is reduced to -30 to +650 °C.

The user may also coat the sensor himself, for example using Rust-Oleum® BBQ & Stove enamel.

7.5 Appendix on correction for temperature dependence

The IHF01 calibration reference temperature is 20 °C. In practice, the sensitivity of an IHF01 may depend on the temperature of the sensor.

The temperature dependence of the IHF01 is specified as < 0.1 %/°C.

The actual temperature dependence is not known. Based on the thermal conductivity of the sensor material as a function of temperature, the thermal expansion of the sensor materials, and the Seebeck coefficient of the thermocouple as a function of temperature, we find a theoretical value for the temperature dependence of the sensitivity of -0.05 %/°C.

Users may wish to correct for this temperature dependence.

To correct for the temperature dependence of the sensitivity, use the measurement function

$$\Phi = U/(S \cdot (1 - 0.0005 \cdot (T - 20))) \quad (\text{Formula 7.5.1})$$

with Φ the heat flux in W/m², U the IHF01 voltage output in V, S the sensitivity in V/(W/m²) at 20 °C and T the IHF01 temperature.

S is shown on the product certificate.

7.6 Appendix on measurement range for different temperatures

The measurement range of FHF01 is specified as $(-1000 \text{ to } +1000) \times 10^3 \text{ W/m}^2$ at $20 \text{ }^\circ\text{C}$ heatsink temperature. This is a very conservative specification.

In reality, the maximum temperature of $+900 \text{ }^\circ\text{C}$ is the limiting specification. The sensor temperature T in $^\circ\text{C}$ in a specific situation depends on the heatsink temperature T_{heatsink} in $^\circ\text{C}$, the heat flux Φ in W/m^2 and the thermal resistance per unit area $R_{\text{thermal,A}}$ of the sensor in $\text{K}/(\text{W/m}^2)$.

$$T = T_{\text{heatsink}} + \Phi \cdot R_{\text{thermal,A}} \quad (\text{Formula 7.6.1})$$

This means the measurement range is lower for higher heat sink temperatures.

$$\Phi_{\text{maximum}} = (900 - T_{\text{heatsink}}) / R_{\text{thermal,A}} \quad (\text{Formula 7.6.2})$$

Table 7.6.1 shows measurement ranges for different heatsink temperatures. The heatsink temperature in this context is the temperature of the object on which the IHF01 is mounted.

Table 7.6.1 measurement range for different heatsink temperatures

HEATSINK TEMPERATURE	MEASUREMENT RANGE
20 $^\circ\text{C}$	$2600 \times 10^3 \text{ W/m}^2$
50 $^\circ\text{C}$	$2550 \times 10^3 \text{ W/m}^2$
100 $^\circ\text{C}$	$2500 \times 10^3 \text{ W/m}^2$
200 $^\circ\text{C}$	$2400 \times 10^3 \text{ W/m}^2$
300 $^\circ\text{C}$	$2200 \times 10^3 \text{ W/m}^2$
400 $^\circ\text{C}$	$1950 \times 10^3 \text{ W/m}^2$
500 $^\circ\text{C}$	$1650 \times 10^3 \text{ W/m}^2$
600 $^\circ\text{C}$	$1300 \times 10^3 \text{ W/m}^2$

7.7 Appendix on use in (potentially explosive) environments

IHF01 is optionally supplied with a product certificate specifying the ATEX rating as II 2G Ex db IIC T6.

The formal equipment model names of the IHF01 is LEX35A. The final letter specifies the shielding option: in the standard configuration the shield (grey wire) of the low temperature extension cable is not connected to the transition piece, high temperature cable and sensor body.

Contact Hukseflux for other shielding options. This has an impact on the formal model names:

- LEX35A: shield not connected to the transition piece, high temperature cable and sensor body
- LEX35B: shield connected to the transition piece, high temperature cable and sensor body

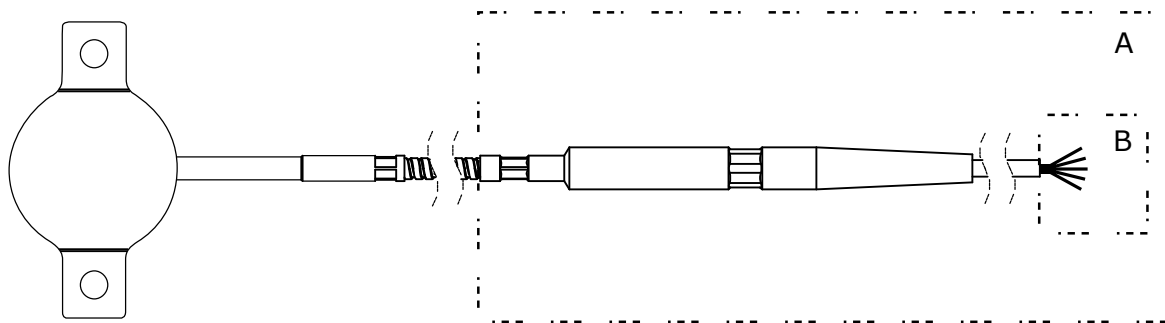

Figure 7.7.1 Only when used with EC type examination certificate (ATEX): IHF01 is certified for use when area A is between -20 and +70 °C, and the cable end (area B) must be provided by the user with an enclosure certified for use in the area of installation.

7.8 EU declaration of conformity



We, Hukseflux Thermal Sensors B.V.
Delftechpark 31
2628 XJ Delft
The Netherlands

in accordance with the requirements of the following directive:

2014/30/EU The Electromagnetic Compatibility Directive

hereby declare under our sole responsibility that:

Product model: IHF01
Product type: Industrial heat flux sensor

has been designed to comply and is in conformity with the relevant sections and applicable requirements of the following standards:

Emission: EN 61326-1 (2006)
Immunity: EN 61326-1 (2006)
Emission: EN 61000-3-2 (2006)
Emission: EN 61000-3-3 (1995) + A1 (2001) + A2 (2005)
Report: 08C01340RPT01, 06 January 2009



Eric HOEKSEMA
Director
Delft
October 17, 2017

