

CD/VCD PICKUP SPECIFICATIONS

Smartech Electronics and Machinery Manufacturing Co., LTD.

3306-3305 BLDG33 No.118 Xiangxi Road

Zhuhai, Guangdong, 519000 P.R. China

<http://www.vcdpickup.com> zhimpexp@pub.zhuhai.gd.cn

CONTENTS

1. Scope of Document
2. Evaluation Conditions
3. Absolute Maximum Rating
4. Performance Specifications
 - 4.1 General
 - 4.2 Actuator
 - 4.3 Electrical characteristics
5. Reliability Assurance
 - 5.1 Reliability Test Standard
 - 5.2 Reliability Specification
6. Dimension
7. Optical Structure
8. Pin Connection
9. APC Power Supply
10. Standard evaluation circuit
11. Precautions for handling
12. Conformity of main parts to UL safety standards
13. Semiconductor Laser

1. Scope of Document

- ★ This document describes the specification of optical pickup for use in compact disc players (including audio CD and Video CD).
- ★ The contents of this specifications manual are subject to change for the purpose of improvement by prior discussion of both parties.
- ★ If any disagreement should arise, action will be taken to settle the matter upon discussion of both parties based on the content of specifications manual.
- ★ Within the range of these specifications, parts are subject to change without notice for technical improvement.

2. Evaluation Conditions

Measurements of basic performance specifications must be performed under the following conditions.

ITEM	CONDITIONS
Position	Emitting laser light from the horizontally placed objective lens is to by Z axis + direction
Environment	The test should be taken at normal temperature and humidity. If any doubts arise, take the test at a temperature of 20 ~ 25 ℃ and humidity of 50 ± 5%
Test Equipment	PULSTECH made standard inspection equipment. Model: OPAS 1000A Jitter Meter: Meguro MJM-6318 Leader LJM-1851 APC power supply (See chapter 9) Standard measurement circuit (See chapter 10) Oscilloscope(100MHz)
Evaluation disc	SONY: YEDS-18 A-BEX: TCD784

Note: This document adopts SI unit.

3. Absolute Maximum Rating

ITEM		SPECIFICATIONS	REMARKS
Actuator coil current	Focus ing coil	200mA RMS (continuous)	0mA for tracking coil
	Tracking coil	200mA RMS (continuous)	0mA for focus ing coil
Laser diode reverse voltage		2 V	Focusing
Monitor pin photo diode reverse voltage		30 V	
6-segment photo diode forward current		10 mA	

4.Performance Specifications

4.1 General

ITEM		SPECIFICATION	
optical	Lens	Focus length (f)	3.86 mm
		Numerical aperture (NA)	0.45
		Working distance (WD)	2.1 mm
	Laser diode	Laser wavelength (λ)	760~800 nm
	Servo error detect method	Focusing error	Astigmatism method
		Tracking error	3-spot method
Direction of Lens Movement	Focusing Direction	A positive voltage applied to Pin 13 of Actuator/Laser diode connector moves the objective lens toward disc.	
	Tracking Direction	A positive voltage applied to pin 14 of Actuator/Laser diode connector moves the objective lens toward the center of the disc.	
Mechanical	Dimension		See chapter 6
	Mass Weight		23±1 g
	Moving mass of actuator		1.8g
Electrical	Power supply voltage for LD		Single power supply +5V
	PD signal output method		Voltage output

4.2 Actuator

ITEM		STANDARD VALUE (ROOM TEMPERATURE)	REMARKS
FOCUSING	Movable distance	$> \pm 0.7 \text{ mm}$	With respect to design center position
	DC resistance	$7.0 \pm 1 \ \Omega$	
	Sensitivity	$1.6^{+1.0}_{-0.6} \text{ mm/V}$	Specified at 5 Hz
	Resonant frequency (fo)	$20 \pm 4 \text{ Hz}$	Specified at Maximum Q value
	Q value	$15 \pm 5 \text{ dB}$	$Q \text{ value} = \text{Gain}(fo) - \text{Gain}(5\text{Hz})$
	Phase	1 KHz	$195 \pm 7 \text{ deg}$
5 KHz		$224 \pm 7 \text{ deg}$	
TRACKING	Movable distance	$> \pm 0.5 \text{ mm}$	With respect to design center position
	DC resistance	$7.0 \pm 1 \ \Omega$	
	Sensitivity	$1.0^{+0.8}_{-0.4} \text{ mm/V}$	Specified at 5 Hz
	Resonant frequency (fo)	$18 \pm 4 \text{ Hz}$	Specified at Maximum Q value
	Q value	$20 \pm 5 \text{ dB}$	$Q \text{ value} = \text{Gain}(fo) - \text{Gain}(5\text{Hz})$
	Phase	1 KHz	$182 \pm 7 \text{ deg}$
5 KHz		$192 \pm 7 \text{ deg}$	

4.3 Electrical characteristics

ITEM		STANDARD (ROOM TEMPERATURE)	REMARKS
RF Signal	Level	1.0±0.2 Vp-p	APC temperature characteristics exclude
	Jitter Level	<30ns	Use a standard jitter measuring device
	Crosstalk	$\frac{V2}{V1} < 45\%$	
	Variation of RF signal envelope	The variation of RF signal envelope must be less than 30% when the objective lens moves±0.35mm	
Focus Error Signal	S-curve Amplitude	20±6 Vp-p	S-curve p-p:10.5µm
	Defocusing	<±1µm	Focus bias at Optimum jitter level  defocus= v2 / v1 *10.5µm
	Polarity	The focus error signal changes from minus to plus when the objective lens approaches the disc.	
Tracking Error Signal	Amplitude	14±6 Vp-p	
	E-F balance	$\frac{V2}{V1} < 20\%$	
	E-F different phase	<60 deg	
	Polarity	When the laser spot is off track toward the center of the disc, tracking signal is defined as plus. (See Fig 4.3)	

Fig 4.3



5. Reliability Assurance

5.1 Reliability Test Standard

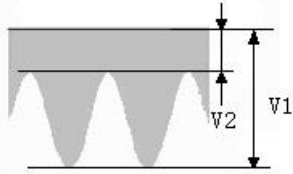
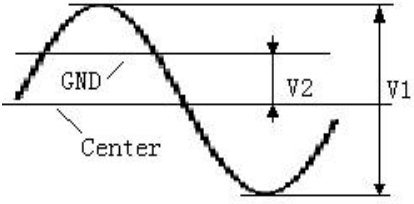
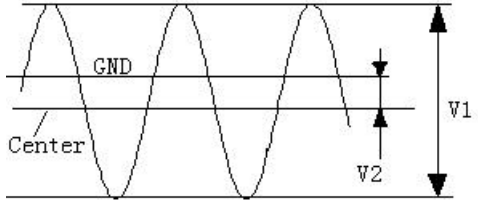
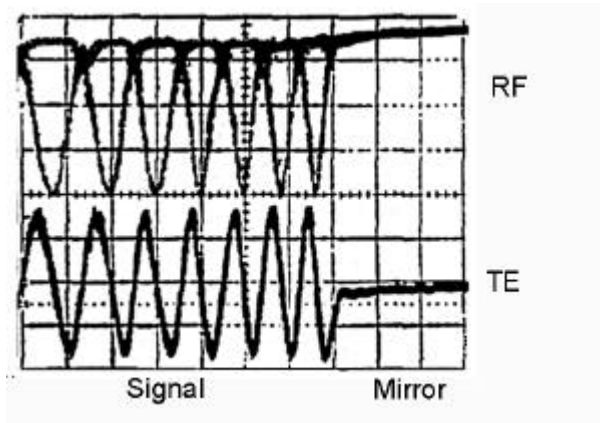
ITEM	CONDITION	TEST METHOD
Operating Temperature	-5 to 55 °C	Leave the pick-up in the idle state within this temperature range for 4 hours. Then age it for 10 minutes at the same temperature and take performance data. Do not allow condensation to form on the lens and actuator.
Storage Temperature	-30 to 60 °C	Leave the pickup at temperature in the above range for 24 hours and then at room temperature for over 16 hours. Take performance after aging. Do not let condensation form on the lens and actuator.
Storage in Hot and Humid Conditions	Temperature: 60 °C Humidity: 90%	Leave the pickup at the above temperature and humidity for 48 hours and then at room temperature for over 16 hours. After aging, take the performance data. Do not let condensation form on the lens and actuator.
Vibration	Amplitude: 2mm Frequency: 13-25Hz Sweep: linear Directions:4 (vertical and horizontal)	Subject the pickup to vibrations under the above conditions for 20 minutes in each direction (time for return sweep: 1 minute). Then take the performance data.
Impact	80G three directions	Use impact test machine

5.2 Reliability Specifications

(Deviations from initial value after reliability tests under the conditions specified)

ITEM		STANDARD VALUE	
Actuator	Focusing	Sensitivity	< ±20 %
		Resonant frequency (fo)	< ±2 Hz
		Q value	< ±3 dB
		Phase	1 KHz
	5 KHz		< ±7 deg
	Tracking	Sensitivity	< ±20 %
		Resonant frequency (fo)	< ±2 Hz
		Q value	< ±3 dB
Phase		1 KHz	< ±5 deg
	5 KHz	< ±7 deg	
Optics	RF signal	RF level	< ±15%
		Jitter level	< 5 ns
		Crosstalk	< 15 %
	Focusing error signal	S-curve amplitude	< ±20 %
		Defocusing	< ±1 μm
	Tracking error signal	Traverse	< ±30 %
		E-F balance	< 10 %
E-F phase difference		< 30 deg	
Service Life of Laser Diode	After 3,000 hours operation at 25 °C, defective rate is under 0.1% (excluding damage due to electrostatic discharge)		

6. Dimension

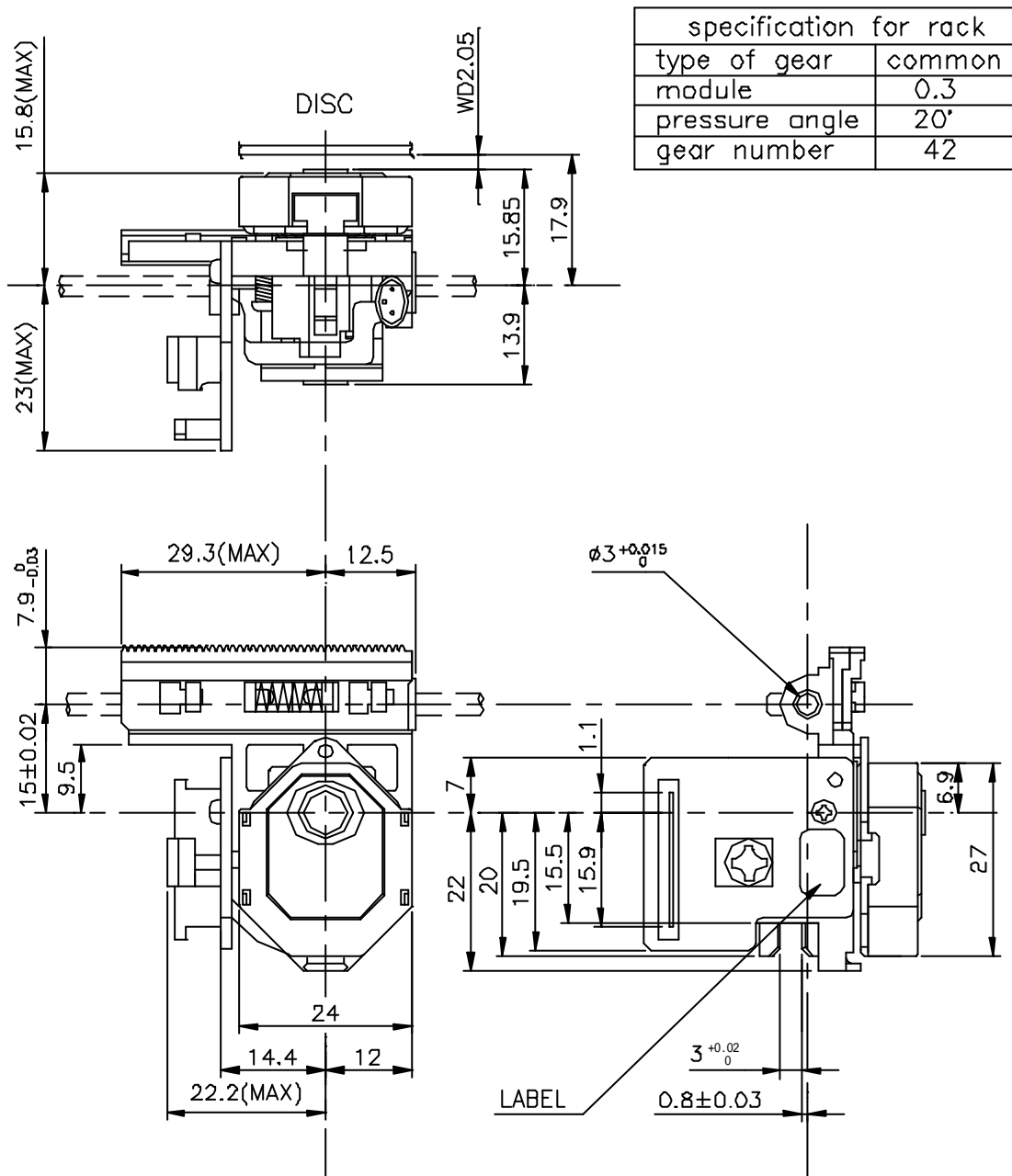

7. Optical Structure

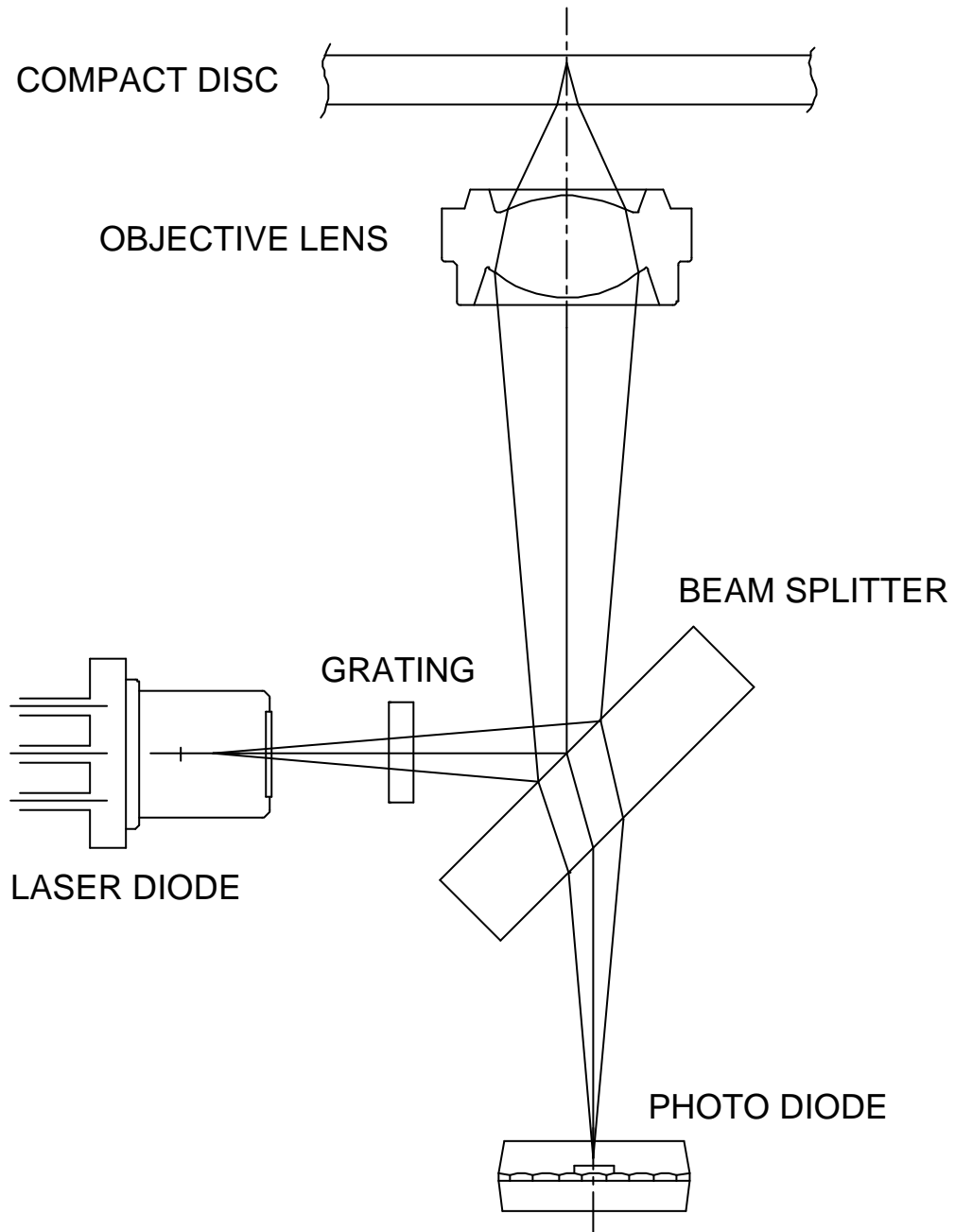

8. Pin connection

Pin No	Name
1	PDIC Vc
2	Vcc
3	E
4	D
5	A
6	B
7	C
8	F
9	GND
10	LD LD
11	VR
12	PD
13	F+
14	T+
15	T-
16	F-

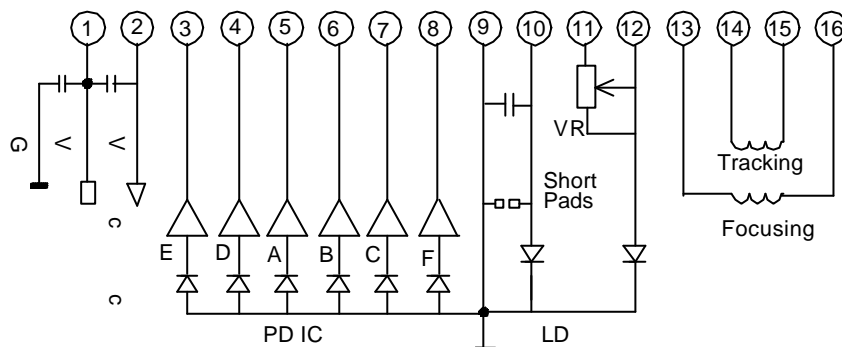
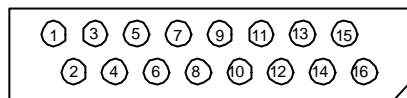
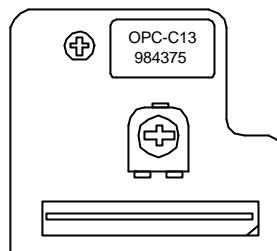

Z
+
S
D
)
(

||

<

9. APC Power Supply (Reference)

Single +5V

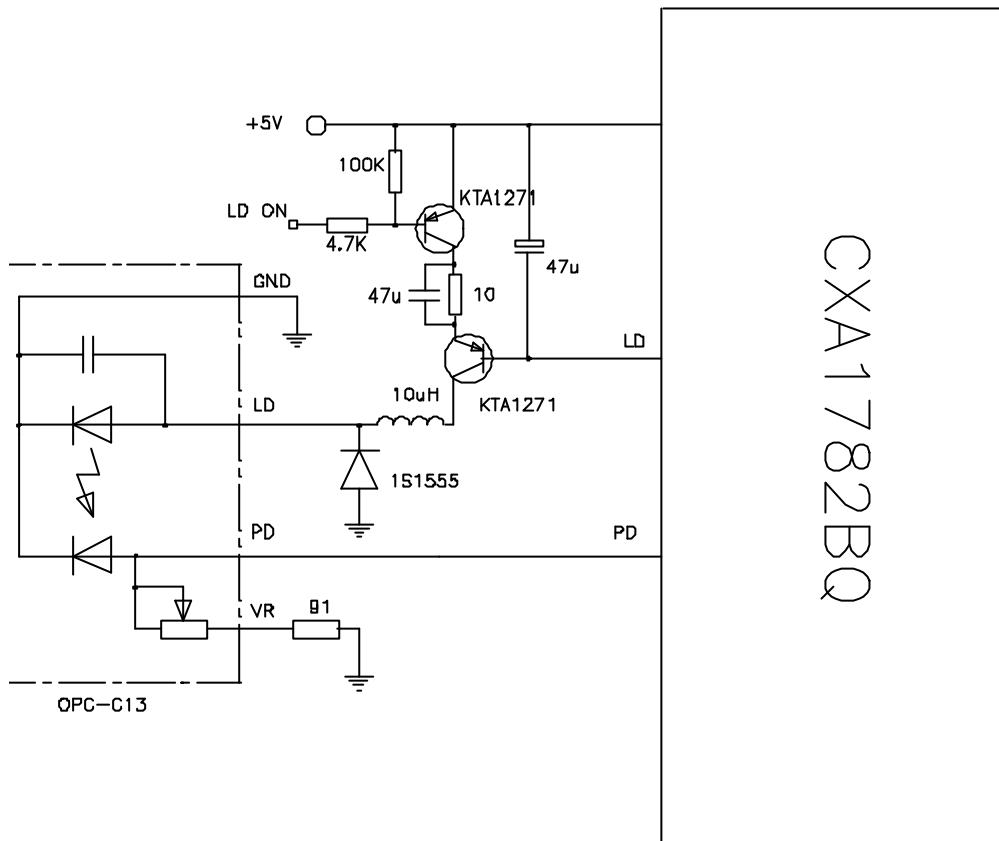

10. Standard evaluation circuit

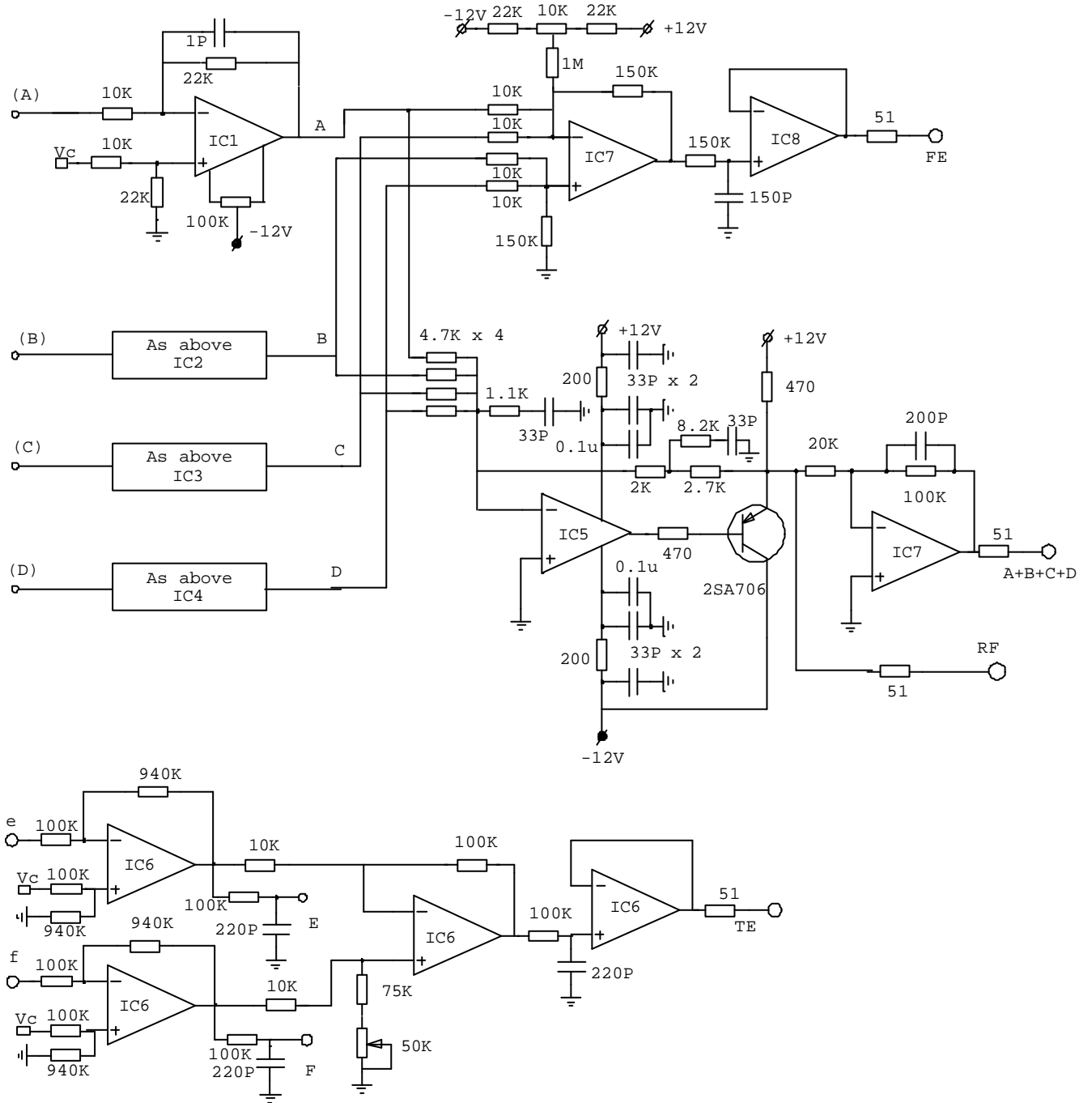

IC1~4: LM6361
 IC5: LF357
 IC6~8: TL084
 Vc = Vcc/2
 Vcc: Pickup Supply Voltage(+5v)

11. Precautions for handling

Following attentions should be paid when handling the pickup. Make sure the service person and users are aware of them too.

11.1 Precautions for general handling.

OPC-C10A is comprised of precision mechanical and optical components and carefully assembled and adjusted in factory, so that do not attempt to disassemble or readjust it.

Do not drop the pickup, avoid shock, rough handling or leaving the pickup in the environment with high temperature / high humidity or dusty place.

11.2 Precautions for handling the laser diode

1) Do not attempt to adjust the trimmer.

Radiant power output and other characteristics of the laser diode are critically subject to the ambient temperature. Output of laser diode is stabilized by pre-adjusting the trimmer on circuit board of pickup in factory, and the external APC power supply circuit. An excessive output of laser will deteriorate the life of laser diode.

2) Avoid current surges and electrostatic discharges

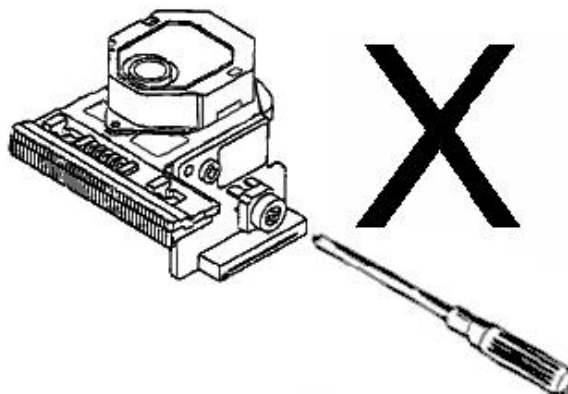

Due to the structure and operating principles of laser diode, LD may deteriorate on current surges caused by switch and high speed pulse cause by electrostatic discharge.

Protective circuit should be provided to prevent damages by current surges.

Ground human body by a wrist strap, measuring equipment, jigs, and tools. Use of a grounding mat on the worktable and floor is recommended

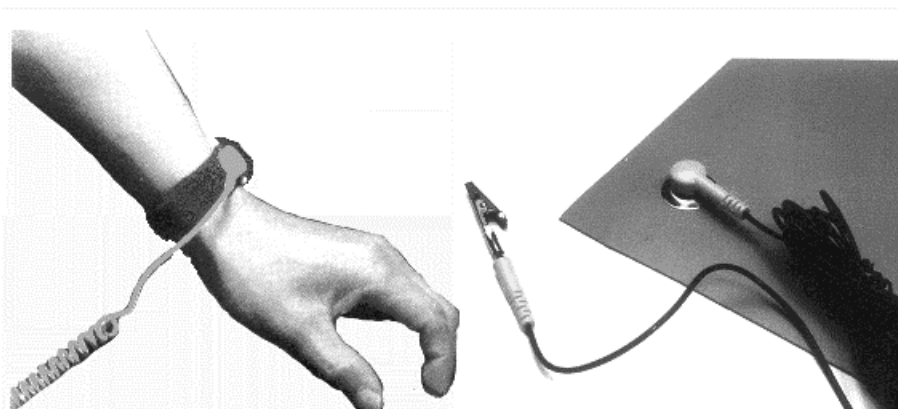

LD terminals are factory-strapped before shipment to protect LD from electrostatic discharges during transportation. After connector insertion, unstrap the LD terminal with a solder iron. The temperature of the solder iron must be under 320°C and the unstrapping should be performed quickly.

11.3 Handling actuator

- 1) The characteristic of the actuator may be changed if a magnetic object is located nearby. Since the actuator use powerful magnet, do not allow foreign materials to enter through gap in the cover.
- 2) When the lens has dust, dirt, fingerprint or oil on it, the characteristics of pickup such as jitter, RF level may be degraded. Clean the lens with a lint free cotton bar moistened with isopropyl alcohol.

12. Conformity of main parts to UL safety standards

Part Name	Material Manufacturer	Grade	Generic Name	Type No.	UL file No.
Optical Base	Polyplastics Co., Ltd Tokyo, Japan	94V-0	PPS	6165A	E109088
Actuator Cover	Daicel Chemical Industries Ltd. Japan	94V-0	POM	SER-90	E47773
PD Base	Polyplastics Co., Ltd Tokyo, Japan	94V-0	PPS	6165A	E109088
Slide Rack	Polyplastics Co., Ltd Tokyo, Japan	94V-0	POM	94HB	M90-44
Flexible PCB	Torita Group Co., Inc. Zhuhai,Guangdong, PR.China	94V-0	FPCB	TFC-1	E162630

13. Semiconductor Laser

Part Name	Material Manufacturer	Product Name
Semiconductor Laser	Rohm Corporation	RLD-78MA